

Transmitted Light Process Refractometer

Features

Sensor

- unique transmitted light process refractometer
- zero point stable and thermally drift-free due to difference measurement of two measuring beams generated by a biprism
- one sensor type for all relevant process fluids applicable as the accuracy is constant in a wide range of refractive indices
- integrated Pt1000 probe for fast temperature compensation
- analysis of signal amplitude to determine the fluid turbidity or to detect coatings on the prism
- internal self diagnosis for rapid error detection
- compact design and thermal insulation of the sensor electronics
- one-sided pipe access as the light is reversed in the sensor
- sapphire optics with high chemical resistance and mechanical hardness
- various sensor types and process connections for different pipes and vessels

Transmitter

- calculation of customer specific output quantities, e.g. mass concentration of components in solutions
- standard applications included, e.g. determination of the sugar concentration in °Brix
- easy modeling of customer specific fluid data sets by means of the program RMKoeff or in the FLEXIM laboratory
- measurement of three-component mixtures on the basis of external quantities, e.g. sound velocity, density, conductance

Measurement

- not sensitive to pressure and temperature fluctuations in the process
- not sensitive to bubbles compared to other measuring methods
- no minimum flow required
- independent of viscosity



Sensor PIOX[®] R400, type of construction M



Sensor PIOX[®] R400, type of construction L

Common Fields of Application

- concentration measurement, e.g. during distillation, rectification, solvent recovery
- process and quality control

Chemical Industry

- acids, e.g. sulfuric acid, hydrochloric acid, acetic acid, hydrogen peroxide
- solvents of metal salts, e.g. chlorides, phosphates, sulfates
- organic solvents:
 - alcohols, glycols
 - amines, e.g. MEA, DEA, EDA
 - pyrrolidones, e.g. NMP, PVP
 - acetone
- fungicides
- polymers and polymerization control

Textile Industry, Fiber Production

- caprolactam
- cellulose spinning solution
- polycarbonate
- dimethylformamide (DMF)
- dimethylacetamide (DMAC)

Paper and Glue Production

- starch concentration
- solids content in starch and casein based glues
- monitoring of solving process in glue production

Food and Beverage Industry, Biochemicals

- vitamin C production: ascorbic acid, ketogulonic acid
- citric acid, acetic acid
- pectin
- beet and cane sugar production
- sweets
- original wort (cold and hot wort) in the beer production
- alcohol in wine and spirits
- whey
- soft drinks, fruit juices

Research, Optics

- concentration measurement during the crystal growth process
- process control of special etching solutions

Measuring Principle

The refractive index n of a solution is determined by means of transmitted light refractometry. A light beam propagates through the solution and will be refracted at the interface to a prism. The angle of refraction will be measured by a detector. The refractive index n of the solution can be calculated from Snell's law of refraction:

$$n_i \cdot \sin\theta_i = n_t \cdot \sin\theta_t$$

with

- n_i - refractive index of fluid
- θ_i - angle of incidence
- n_t - refractive index of prism
- θ_t - angle of refraction

Measurement with Refractometer PIOX R400

Measurement in the Sensor

The light source is a special LED with a wave length $\lambda = 590$ nm (sodium D-line). The light passes an aperture, will be parallelized by a lens and reversed by a Dove prism. Then it enters the fluid through a window in the sensor head. When the light beam re-enters the sensor, it will be split at the vertex of a biprism and refracted at its inclined edges.

The two resulting measuring beams will be focussed by a lens projecting sharp images of the aperture on the detector, a CCD sensor with 2048 pixels.

The angle of refraction will be determined from the difference between the two measuring beam projections. The zero point will be calculated continuously, thus eliminating influences of process pressure and temperature.

The following values will be measured/calculated in the sensor and sent to the transmitter:

- refractive index n_D (= matched to the sodium D-line) calculated from the angle of refraction
- fluid temperature measured by the integrated Pt1000 temperature probe
- signal amplitude calculated from the CCD signals
- internal sensor temperature
- relative humidity measured in the sensor electronics

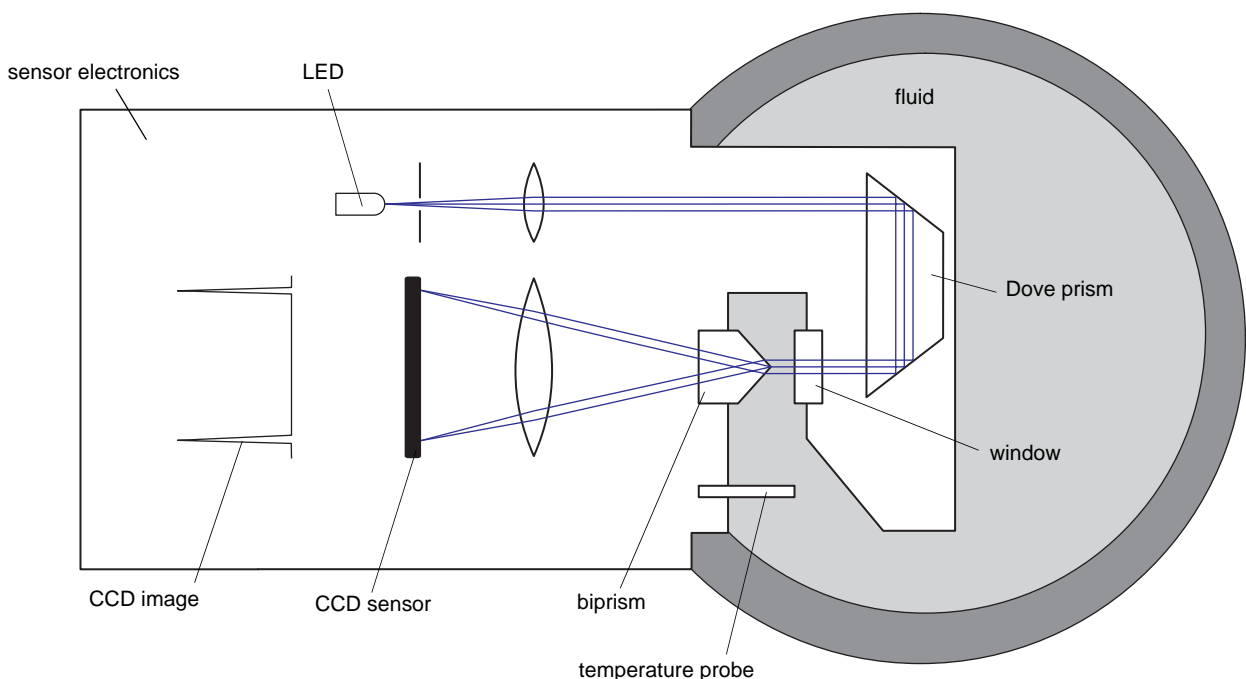

Processing in the Transmitter

The refractive index and the fluid temperature received from the sensor will be used for the calculation of the process parameters as the temperature compensated refractive index nDT, the °Brix value or the concentration in mass percentage or volume percentage. Additional process parameters can be configured by means of the program RMKoeff (see page 5).

The transmitter can be equipped with electrical inputs so that further available fluid quantities, e.g. the sound velocity, the density or the conductance can be fed and used for the measurement of three-components mixtures.

Temperature Dependency

The process parameters can often be calculated only if the fluid temperature is known since the refractive index depends on the fluid temperature. The fluid temperature measured by the integrated temperature probe will be used for the calculation of the temperature compensated refractive index nDT.

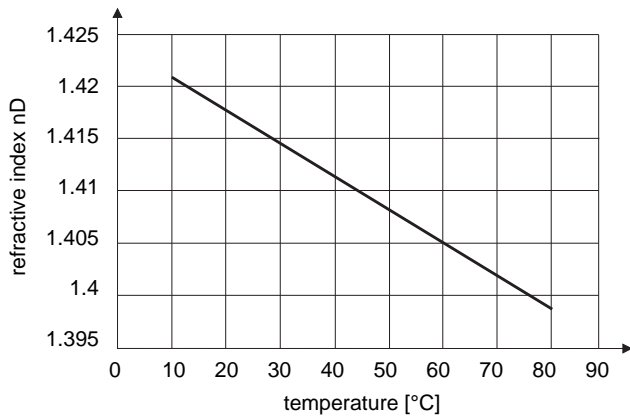

Refractive index nD as a function of temperature (concentration = constant)

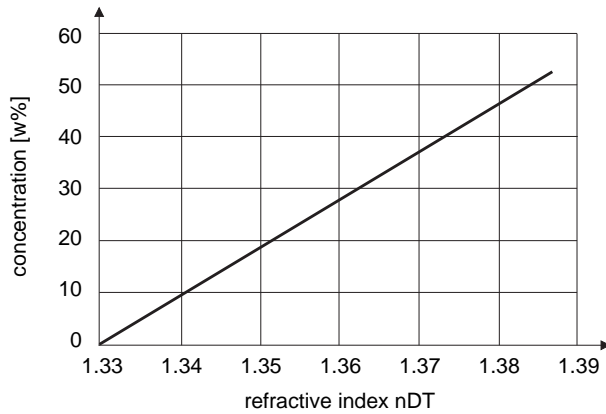

Concentration as a function of refractive index nDT (temperature = constant)

Program RMKoeff

The transmitter has an internal database for the data sets of commonly used fluids. Data sets for additional fluids can be easily added and managed on a PC by means of the program RMKoeff.

The characteristics will be generated by polynomials of grade 1...3 from a data table or from a test series. The X axis quantity is the refractive index nDT related to a standard temperature. The Y axis quantity is the required process parameter. The process parameter and its unit of measurement are user defined, e.g. concentration in w%, g/l or mol/l.

The customized data sets will be transferred between transmitter and PC via the serial interface RS232 or USB.

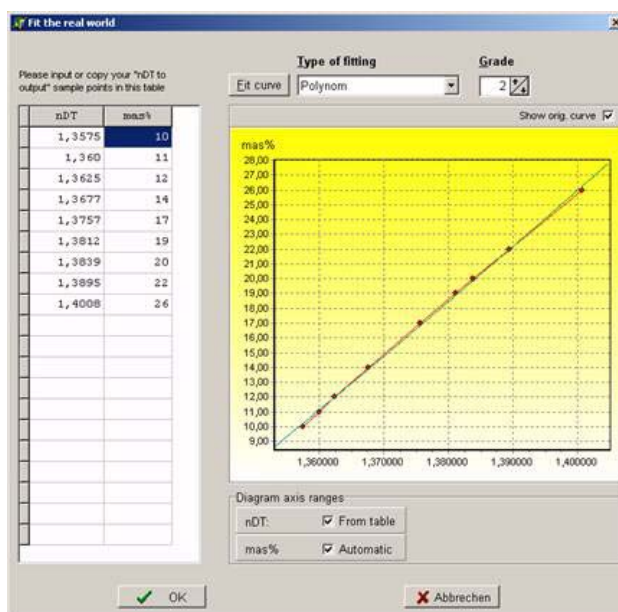

Program RMKoeff - generation of a concentration characteristics

Data sets even with high complexity can also be generated in the FLEXIM laboratory.

Measuring Setups

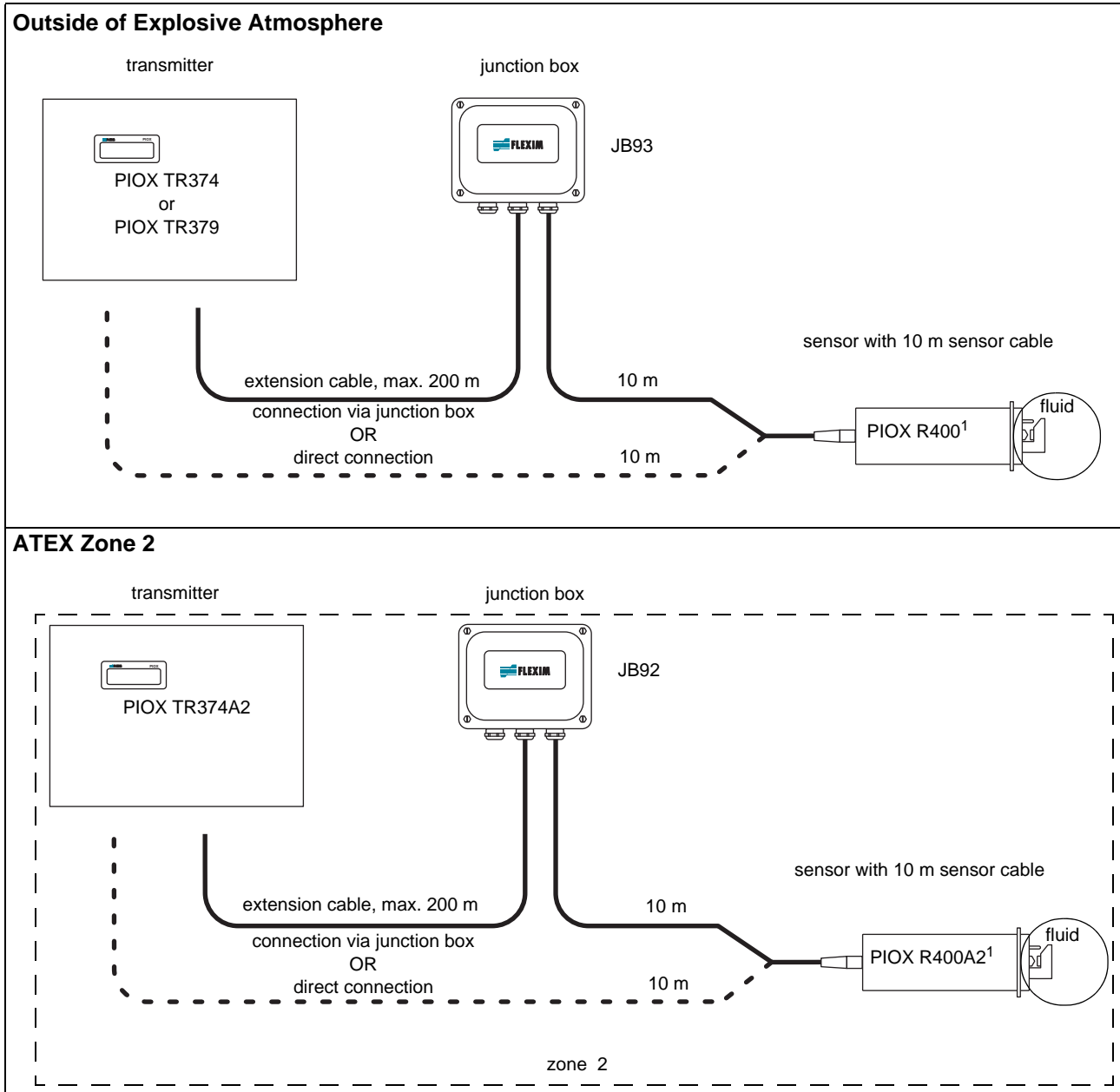

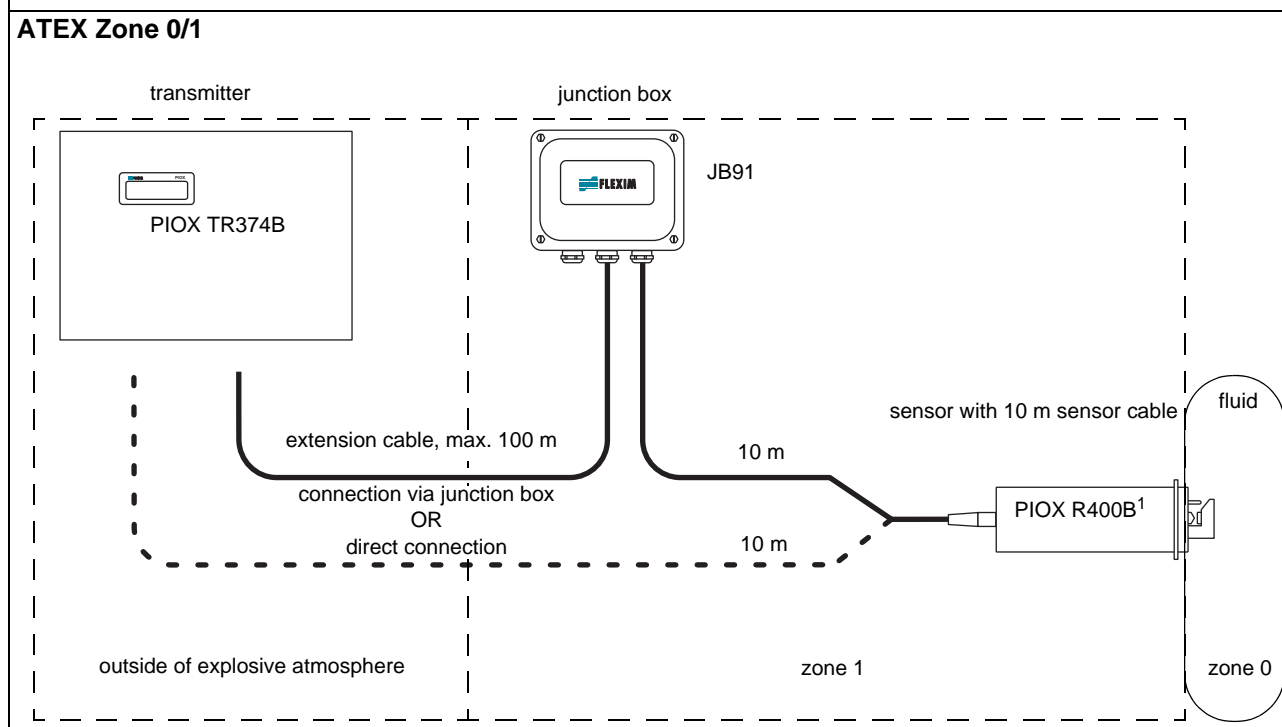
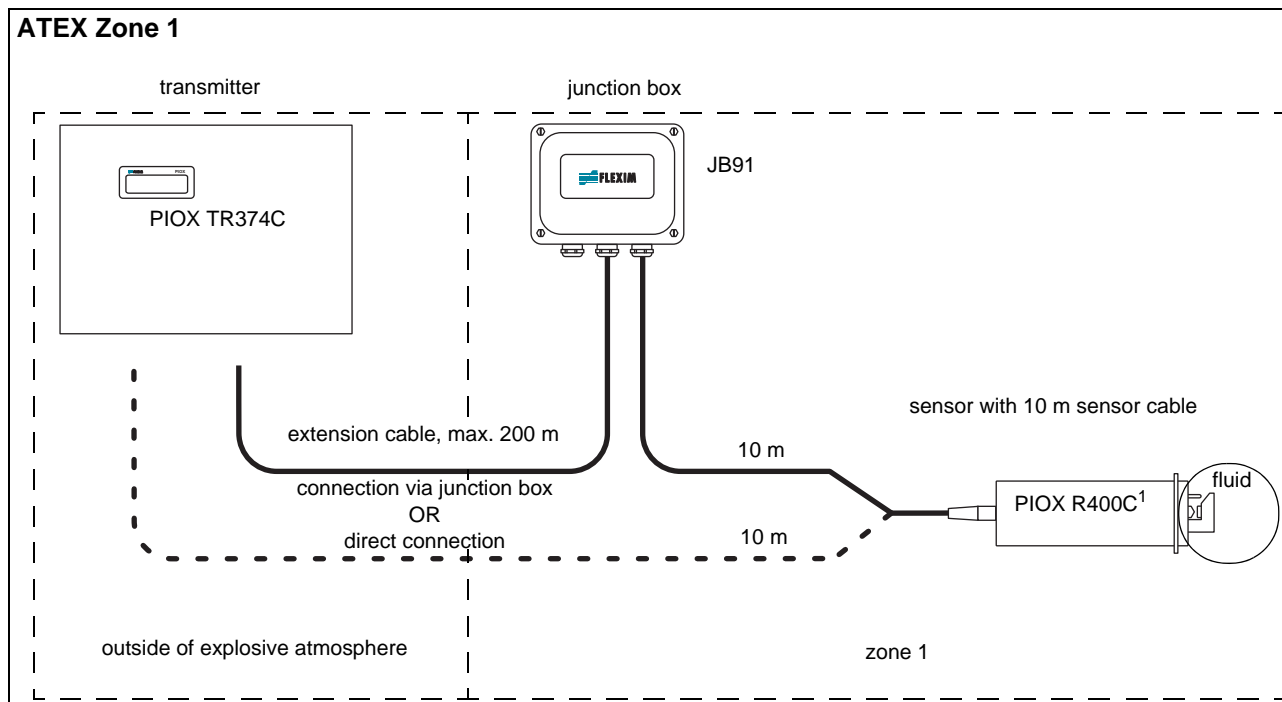

¹ option: connection of 2 sensors



¹ option: connection of 2 sensors

Transmitter

Technical Data

transmitter PIOX	TR374	TR374A2	TR374B	TR374C	TR379
	standard field device	field device for ATEX zone 2	field device for connection of sensors in ATEX zone 0/1	field device for connection of sensors in ATEX zone 1	19 " module
					
power supply	100...240 V/50...60 Hz or 20...32 V DC				
power consumption	< 15 W				
measuring channels	1, option: 2				
signal damping	0...100 s, adjustable				
response time	1 s				
material	aluminum, powder coated				aluminum
degree of protection according to EN 60529	IP 65				IP 20
dimensions	see dimensional drawing				42TE x 3HE (without back panel) see dimensional drawing
weight	2.8 kg				1.7 kg
installation	wall mounting, option: 2 " pipe mounting				19 " rack mounting
operating temperature	-10...+60 °C				
display	2 x 16 characters, dot matrix, backlit				
menu language	English, German				
data logger (option)	SD card 2 GB				-
explosion protection					
ATEX zone	-	2	outside of explosive atmosphere	outside of explosive atmosphere	-
marking	-	CE Ⓜ II 3G Ex nA II T4 T _a -40...+60 °C	CE 0044; Ⓜ II (1)G [Ex ia] IIB T _a -40...+60 °C IBExU06ATEX1075 X	CE 0044; Ⓜ II (2)G [Ex ib] IIC T _a -40...+60 °C IBExU06ATEX1075 X	-
certification	-	-	-	-	-
type of protection	-	non sparking	-	-	-
remark	-	-	intrinsically safe power supply for ATEX zone 0/1 sensors included	intrinsically safe power supply for ATEX zone 1 sensors included	-
measuring functions					
physical quantities	refractive index, fluid temperature, °Brix, w% (saccharose, fructose, glucose, invert sugar), further by RMKoeff				
physical quantities for diagnosis	signal amplitude, sensor humidity, sensor temperature				

transmitter PIOX	TR374	TR374A2	TR374B	TR374C	TR379
communication					
interface	- process integration: RS485 (option) - diagnosis: RS232	- process integration: RS485 (option) - diagnosis: RS232 ¹	- process integration: RS485 (option) - diagnosis: RS232	- process integration: RS485 (option) - diagnosis: RS232	- process integration: RS485 (option) - diagnosis: RS232
serial data kit					
software (all Windows™ versions)	RMKoeff: management of fluid data sets				
cable	RS232	RS232 ¹	RS232	RS232	RS232
adapter	RS232 - USB	RS232 - USB ¹	RS232 - USB	RS232 - USB	RS232 - USB
outputs (option)					
	The outputs are galvanically isolated from the transmitter.				
number	on request				
current output					
range	0/4...20 mA				
accuracy	0.1 % of reading ± 15 µA				
active output	$R_{ext} < 500 \Omega$				
passive output	$U_{ext} = 4...24 \text{ V}$, dependent on R_{ext} $R_{ext} < 1 \text{ k}\Omega$				
voltage output					
range	0...1 V or 0...10 V				
accuracy	0...1 V: 0.1 % of reading ± 1 mV 0...10 V: 0.1 % of reading ± 10 mV				
internal resistance	$R_i = 500 \Omega$				
frequency output					
range	0...1 kHz or 0...10 kHz				
open collector	24 V/4 mA				
binary output					
open collector	24 V/4 mA				24 V/4 mA
Reed relay	48 V/0.25 A				48 V/0.25 A
optorelay	32 V/100 mA				-
binary output as alarm output					
- functions	limit				limit
inputs (option)					
	The inputs are galvanically isolated from the transmitter.				
number	max. 4, on request				
current input					
range	active: 0...20 mA passive: -20...+20 mA				
accuracy	0.1 % of reading ± 10 µA				
active input	$U_i = 24 \text{ V}$, $R_i = 50 \Omega$, $P_i < 0.5 \text{ W}$, not short-circuit proof				
passive input	$R_i = 50 \Omega$, $P_i < 0.3 \text{ W}$				
voltage input					
range	0...1 V or 0...10 V				
accuracy	0...1 V: 0.1 % of reading ± 1 mV 0...10 V: 0.1 % of reading ± 10 mV				
internal resistance	$R_i = 1 \text{ M}\Omega$				

¹ connection of the interface RS232 outside of explosive atmosphere (housing cover open)

Dimensions of Transmitter (in mm)

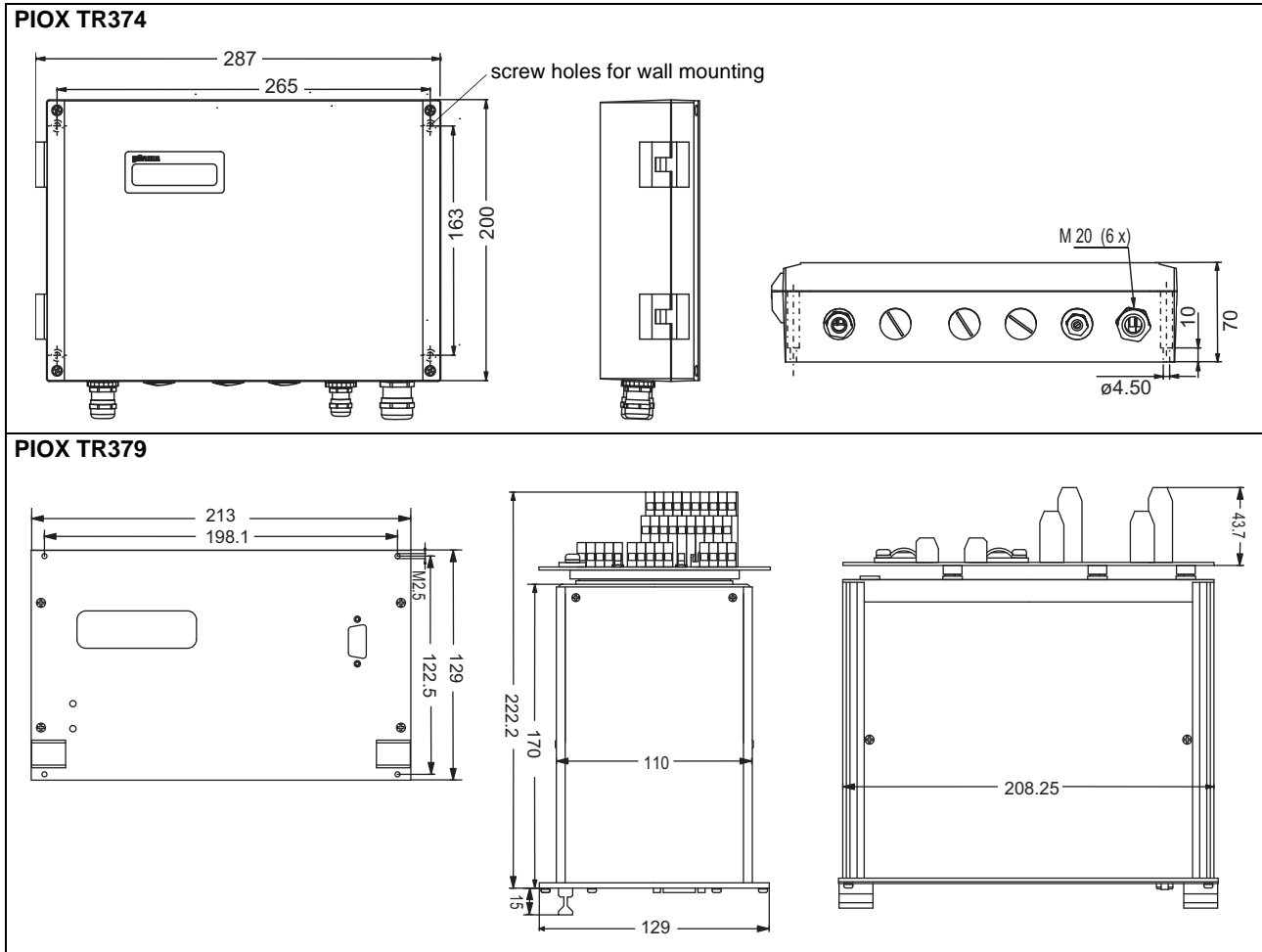

2 " Pipe Mounting Kit (option)

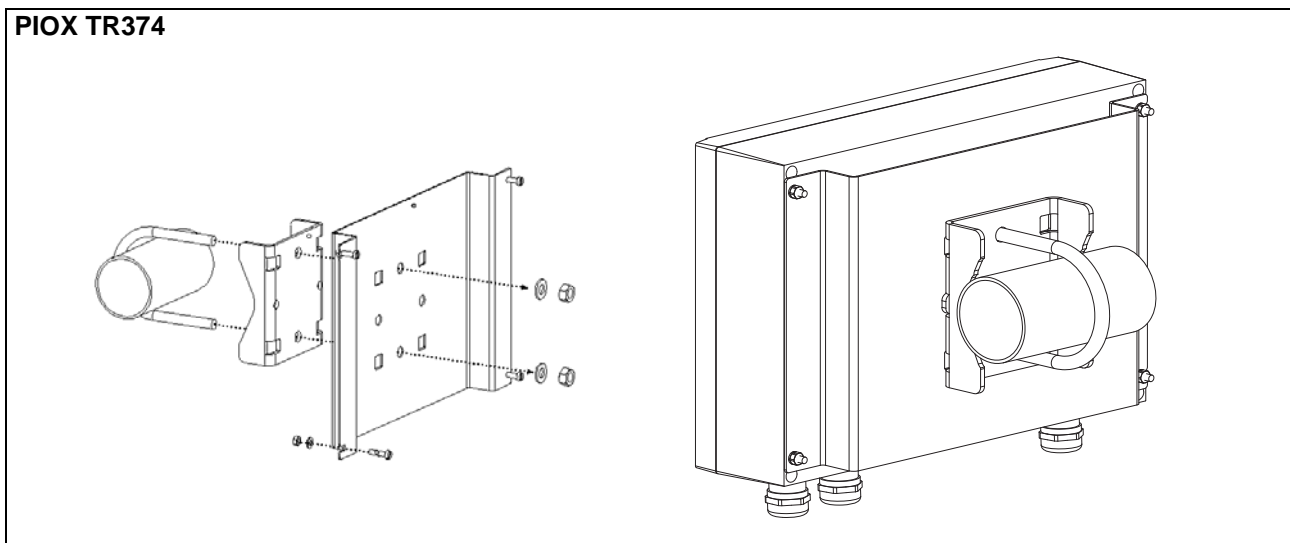

Sensor

Technical Data

sensor PIOX	R400	R400A2	R400B	R400C
process parameters				
medium	all liquids with a turbidity < 10 000 FAU			
fluid temperature (dependent on ambient temperature)	-20...+150 °C (150 °C at an ambient temperature of 20 °C)	-20...+130 °C		
fluid pressure	max. PN 16, on request: max. PN 40			
measurement				
measuring principle	transmitted light refractometry			
measuring range	nD: 1.3...1.7 °Brix: 0...100			
accuracy (absolute)	nD: 0.0002 (corresponds to 0.1°Brix, typical 0.1 w%)			
repeatability	nD: 0.00002 (corresponds to 0.01 °Brix, typical 0.01 w%)			
resolution	nD: 0.000001			
material				
housing	stainless steel 304 (1.4301)			
wetted parts	stainless steel 316Ti (1.4571), special materials on request (e.g. titanium, Hastelloy)			
prism	sapphire, nD ≈ 1.76			
gaskets	EPDM, FKM (Viton) or FFKM (Kalrez)			
degree of protection according to EN 60529	IP 67			
flange	FLEXIM, Varivent or Tri-clamp flange			
dimensions with flange	see dimensional drawing			
weight	type of construction M: 1.7 kg type of construction L: 2.1 kg			
operating temperature	-20...+60 °C			
explosion protection				
ATEX zone	-	2	0/1	1
marking	-	CE Ex II 3G Ex nA II T4 T _a -40...+60 °C T _m -20...+130 °C	CE 0044; Ex II 1/2G Ex ia IIB T4 T _a -40...+60 °C T _m -20...+130 °C	CE 0044; Ex II 2G Ex ib IIC T4 T _a -40...+60 °C T _m -20...+130 °C
certification	-	-	IBExU06ATEX1075 X	IBExU06ATEX1075 X
type of protection	-	non sparking	intrinsic safety	intrinsic safety
temperature probe				
type	Pt1000			
resolution	0.01 K			
accuracy at 20 °C	0.15 K			
sensor cable				
length	10 m			
cable jacket	PVC			
operating temperature	-30...+80 °C			

Dimensions of Sensor (in mm)

	type of construction M	type of construction L
flange type F (FLEXIM flange)	<p>Technical drawing of sensor with flange type F (FLEXIM flange) in construction M. Dimensions: Ø46, 38, 241, Ø70.</p>	<p>Technical drawing of sensor with flange type F (FLEXIM flange) in construction L. Dimensions: Ø46, 150, 241, Ø70.</p>
flange type V (Varivent flange N)	<p>Technical drawing of sensor with flange type V (Varivent flange N) in construction M. Dimensions: 28, 251.</p>	<p>Technical drawing of sensor with flange type V (Varivent flange N) in construction L. Dimensions: 140, 251.</p>
flange type T (Tri-clamp flange 3 ")	<p>Technical drawing of sensor with flange type T (Tri-clamp flange 3 ") in construction M. Dimensions: 38, 241.</p>	<p>Technical drawing of sensor with flange type T (Tri-clamp flange 3 ") in construction L. Dimensions: 150, 241.</p>

Mounting Positions of Sensor

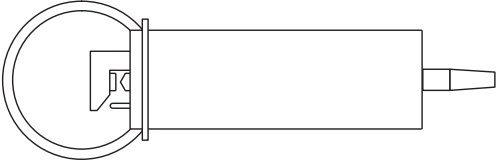
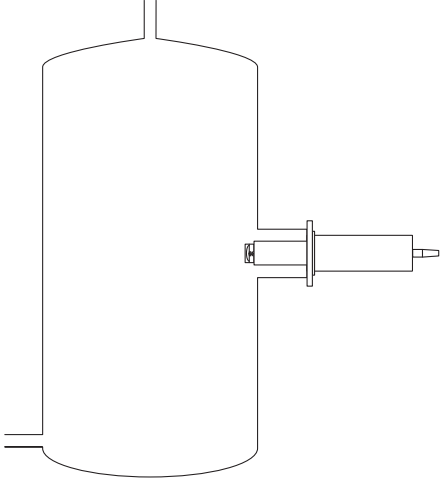
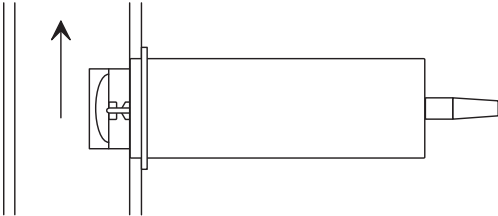
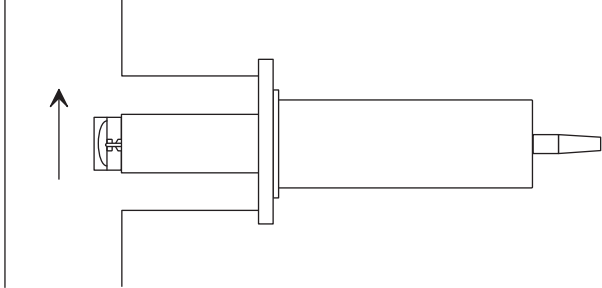
type of construction M	type of construction L
<p data-bbox="194 459 338 483">horizontal pipe</p> 	<p data-bbox="764 459 831 483">vessel</p> 
<p data-bbox="194 1014 312 1039">vertical pipe</p> 	<p data-bbox="764 1014 839 1039">T-piece</p> 

Order Code Key for Sensor

measuring principle	type	-	type of construction	material	gaskets	explosion protection	flange (see page 12)	-	extension cable	description
R										transmitted light refractometer
	400									
			M							normal sensor
			L							long sensor
				S4						stainless steel 316Ti (1.4571)
				Ti						titanium
				PK						PEEK (on request)
				SO						special materials (on request)
					EP					EPDM
					FK					FKM (Viton)
					KR					FFKM (Kalrez)
						A0				ATEX zone 0/1 (R400B)
						A1				ATEX zone 1 (R400C)
						A2				ATEX zone 2 (R400A2)
						NN				without explosion protection (R400)
							F			FLEXIM flange (process connection additionally necessary, see page 15)
							V			Varivent flange N
							T			Tri-clamp flange 3 "
								XXX		cable length in m, for max. length of extension cable see page 19 0 m: without junction box > 0 m: outside of explosive atmosphere with junction box JB93, for ATEX zone 2 with junction box JB92, for ATEX zone 1 and 0/1 with junction box JB91
example										
R	400	-	M	S4	FK	A1	F	-	030	normal sensor with stainless steel housing, Viton gaskets, for ATEX zone 1, with FLEXIM flange, with an extension cable of 30 m and junction box JB91
R	400	-						-		

Process Connections for Sensor

description order code of sensor	order code	pipe diameter	dimensional drawing	dimensions [mm]			max. process pressure [bar]	material		
				l	b	h				
flow chamber with screwed connection to the process pipe option: with cleaning line R400-MxxxxxF	PCR-FTG38PPyy10	G 3/8 "		100	100	100	PN 10	PP		
	PCR-FTG38TFyy10			100	100	100				
	PCR-FTG38S4yy16			100	100	100	PN 16	316Ti (1.4571)		
	PCR-FTG12S4yy16	G 1/2 "		100	100	100				
	PCR-FTG34S4yy16	G 3/4 "		100	100	100				
flow chamber with flanges <ul style="list-style-type: none"> including blind cover including sensor mounting kit (see page 17) option: with cleaning line R400-MxxxxxF	PCR-FD010S4yy16	DN 10		170	∅90		PN 16	316Ti (1.4571)		
	PCR-FD015S4yy16	DN 15		170	∅95					
	PCR-FD020S4yy16	DN 20		176	∅105					
	PCR-FD025S4yy16	DN 25		176	∅115					
	PCR-FD040S4yy16	DN 40		184	∅150					
	PCR-FD050S4yy16	DN 50		190	∅165					
	PCR-FD065S4yy16	DN 65		190	∅185					
	PCR-FD080S4yy16	DN 80		200	∅200		PN 10			
	PCR-FA001S4yy10	ANSI 1 "		201.2	∅108					
	PCR-FA002S4yy10	ANSI 2 "		227	∅152.4					
	PCR-FA003S4yy10	ANSI 3 "		240	∅190.5					
	flow chamber with welded connection to the process pipe <ul style="list-style-type: none"> including blind cover including sensor mounting kit (see page 17) option: with cleaning line R400-MxxxxxF	PCR-FW025S4yy16		DN 25 ANSI 1"		100			100	54
PCR-FW040S4yy16		DN 40	100	100		100				
PCR-FW050S4yy16		DN 50 ANSI 2"	100	100		80				
PCR-FW065S4yy16		DN 65	100	100		91				
PCR-FW080S4yy16		DN 80 ANSI 3"	100	100		106				
Varinline housing type N with welded connection to the process pipe option: with cleaning line R400-MxxxxxV		PCR-VW040S4yy16	DN 40			180	68	72	PN 10	316L (1.4404)
	PCR-VW050S4yy16	DN 50	180		68	84				
	PCR-VW065S4yy16	DN 65	250		68	100				
	PCR-VW080S4yy16	DN 80	250		68	115				
	PCR-VW100S4yy10	DN 100	250		68	134				
	PCR-VW125S4yy10	DN 125	250		68	159				

other process connections, special materials, PN40 on request

yy - select gaskets from order code key (see page 18)

¹ cleaning connection: G1/2 ", internal thread

² other diameters on request

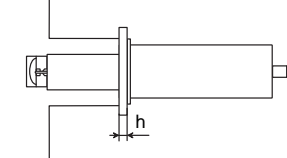
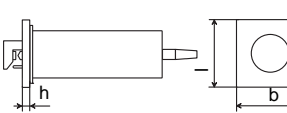
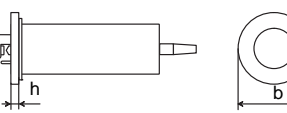
description order code of sensor	order code	pipe diameter	dimensional drawing	dimensions [mm]			max. process pressure [bar]	material	
				l	b	h			
welded flange adapter for pipe mounting with T-piece or for vessel mounting	PCR-DD050S4NN16	DN 50				18	PN 16	316Ti (1.4571)	
	PCR-DD065S4NN16	DN 65				18			
	PCR-DD080S4NN16	DN 80				20			
		PCR-DD100S4NN16		DN 100			20	PN 10	
		PCR-DA002S4NN10		2 "			19.1		
		PCR-DA003S4NN10		3 "			23.9		
	R400-LxxxxxF	PCR-DA004S4NN10		4 "			23.9		
square welding plate • including blind cover • including sensor mounting kit (see page 17)	PCR-WS020S4yy16			100	100	20	PN 16	316Ti (1.4571)	
R400-MxxxxxF R400-LxxxxxF									
round welding plate • including blind cover • including sensor mounting kit (see page 17)	PCR-WR020S4yy16				∅100 ²	20			
R400-MxxxxxF R400-LxxxxxF									

other process connections, special materials, PN40 on request

yy - select gaskets from order code key (see page 18)

¹ cleaning connection: G1/2 ", internal thread

² other diameters on request

Sensor Mounting Kit for PCR-F, PCR-W

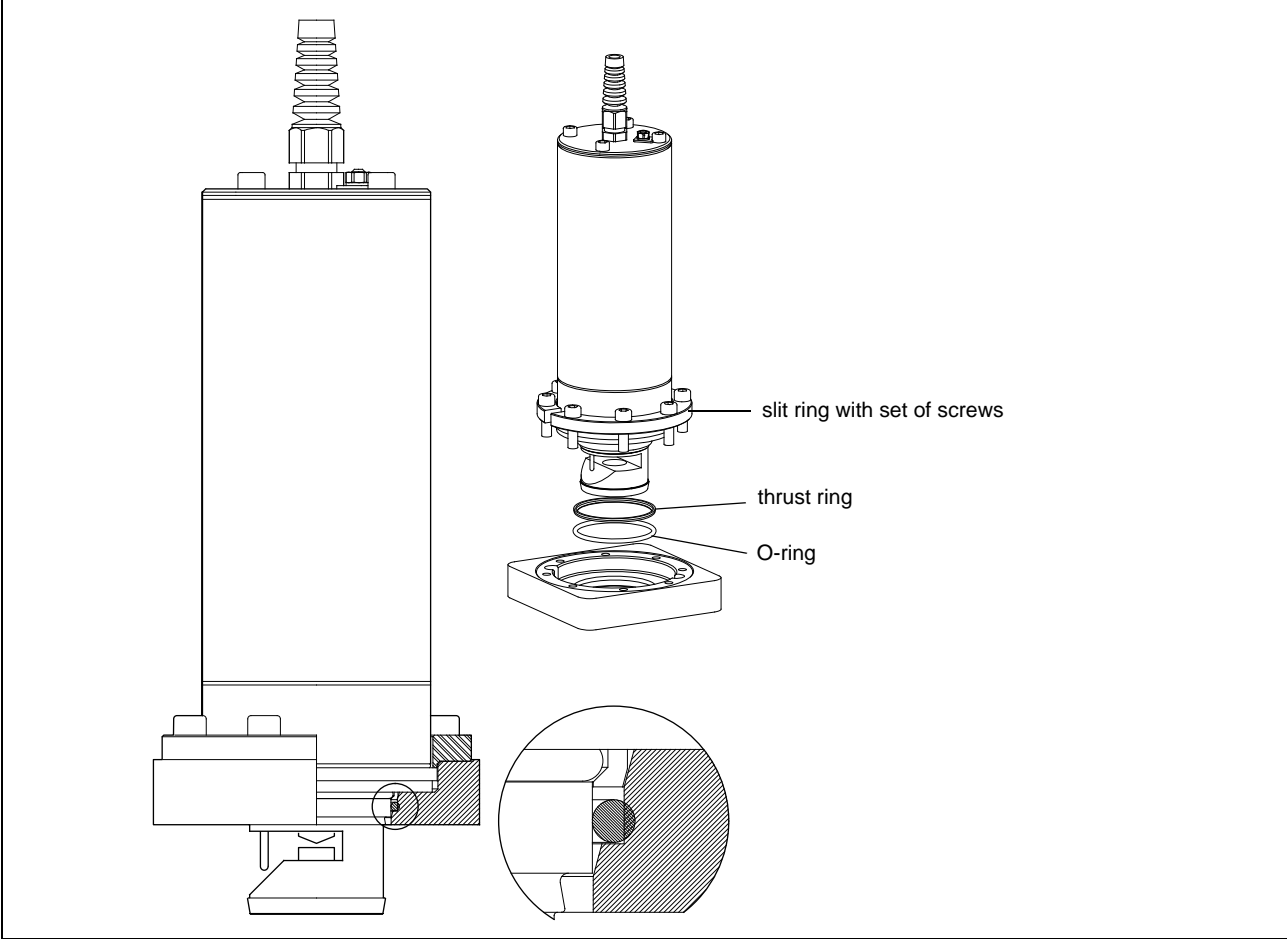

Order Code Key for Process Connections

process connection	-	connection type	pipe connection	pipe diameter ¹	material ¹	gaskets	process pressure ¹	description
PCR								process connection of refractometer
		D						flange adapter for pipe mounting with T-piece or for vessel mounting
			A					according to ASME B 16.5 150 lbs
			D					according to DIN 2633
		F						flow chamber
			A					with flanges according to ASME B 16.5 150 lbs
			D					with flanges according to DIN 2633
			T					screwed connection
			W					welded connection
		V						Varivent connection
			W					welded connection
		W						welding plate
			R					round
			S					square
				XXX				in mm or "
					PP			polypropylene
					S4			stainless steel
					TF			PTFE (Teflon)
						EP		EPDM (not for PCR-D)
						FK		FKM (Viton) (not for PCR-D)
						KR		FFKM (Kalrez) (not for PCR-D)
						NN		no gasket, process connection welded with sensor (PCR-D)
							XX	pressure stage in bar
example								
PCR	-	F	D	050	S4	FK	16	process connection of refractometer with flow chamber and flanges according to DIN 2633, for pipe diameter DN50, material: stainless steel, with Viton gaskets, process pressure PN16
PCR	-							

¹ possible pipe diameters/materials/process pressures to be selected from table on page 15 et seq.

Connection System

Direct Connection

The sensor will be connected directly to the transmitter (cable length = 10 m).

Connection via Junction Box

If the distance of sensor and transmitter is > 10 m, the sensor will be connected via a junction box and an extension cable to the transmitter.

Technical Data of Extension Cable

		ATEX zone 1	ATEX zone 2	outside of explosive atmosphere
type		LIYCY 2x2x0.75/77 blue	LIYCY 2x2x0.75/77 gray	
max. length	m	PIOX R400C: 200 PIOX R400B: 100	200	
operating temperature	°C	-30...+70		

Technical Data of Junction Box

technical type		JB91	JB92	JB93
dimensions		see dimensional drawing		
installation		wall mounting, option: 2 " pipe mounting		
material				
housing		stainless steel 316L (1.4404)	stainless steel 304 (1.4301)	
gasket		silicone	silicone	
degree of protection according to EN 60529		IP 67		
operating temperature				
min.	°C	-40		
max.	°C	+80		
explosion protection				
ATEX zone	°C	1	2	-
marking		not necessary	CE Ⓜ II 3G Ex nA II T6...T4 Ta -40...+80 °C Ⓜ II 3D Ex tD A22 IP67 T 100 °C	-
type of protection	°C	simple apparatus according to IEC 60079-11	non sparking, protection by enclosure	-
remark		only in combination with intrinsic safe equipment [ia], [ib]	-	-

Dimensions of Junction Box (in mm)

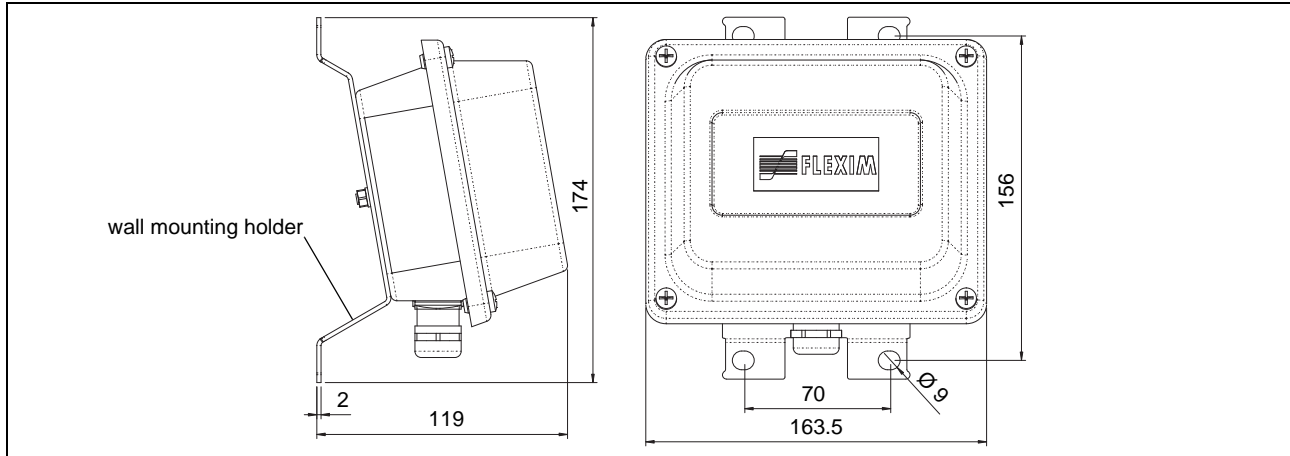

2 " Pipe Mounting Kit of Junction Box (option)

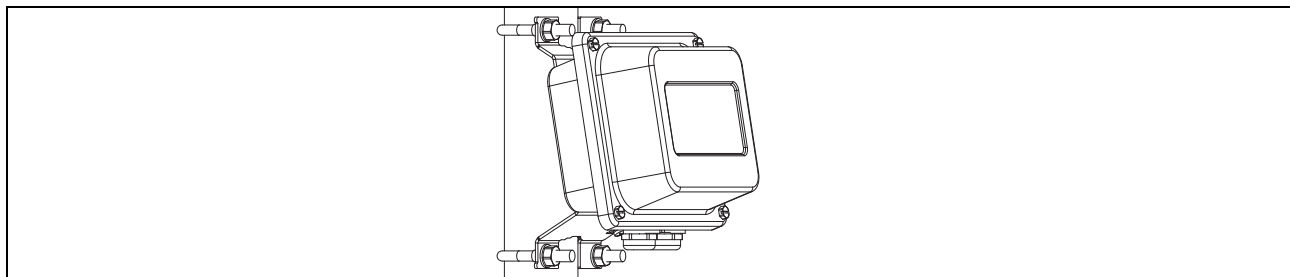



FLEXIM GmbH
Wolfener Str. 36
12681 Berlin
Germany
Tel.: +49 (30) 93 66 76 60
Fax: +49 (30) 93 66 76 80

internet: www.flexim.com
e-mail: info@flexim.com

Subject to change without notification. Errors excepted.
PIOX® is a registered trademark of FLEXIM GmbH.