



A Leap in Refinery Measuring Technology

Non-Intrusive Flow Measurement up to 750 °F Using the WaveInjector®

Reliable. Cost-Effective. Safe.

FCC Feed

Coker Feed

Bitumen

Feedwater

Sump measurement
(long/short resid)

Overflash measurement

Heavy gasoil (HGO)

Heavy vacuum gasoil (HVGO)

Cracker feeders
(thermal, catalytic, hydro)

Heat transfer oil

Measure from outside
what's flowing inside.



720 °F

115 °F



When the Going Gets Hot, We Have the Best Solution:

The multitude of processes in a refinery form a complex system of material and energy flows. From incoming crude to outgoing products, everything is flowing – and for safe and efficient operation, these flows need to be measured.

Harsh process conditions can make heavy demands on flowmeters, especially at temperatures between 400 °F and 750 °F.

Drawbacks of conventional technologies

Traditionally, orifice meters, Coriolis meters and vortex meters are used to measure refinery flows, especially in demanding environments. These well-know conventional flowmeter types have equally well-known shortcomings:

- Intrusive sensors create pressure loss, reducing process **efficiency**.
- Intrusive flow measurement technologies require frequent servicing. Sensors in contact with hot and often dirty hydrocarbons have high failure rates, and pressure taps for orifice plates tend to clog. These high-maintenance measuring technologies reduce **plant availability**.



- In demanding refinery service, high maintenance costs critically undermine **profitability**, especially when the costs of reduced plant availability are taken into account.

FLEXIM's WaveInjector® is simply a better way to measure flow in refineries. This robust non-contact measuring technology is ideal for demanding environments, as proven by its many refinery installations worldwide.

WaveInjector®

State-of-the-Art Ultrasonic Technology for Flow Measurement in Refineries.

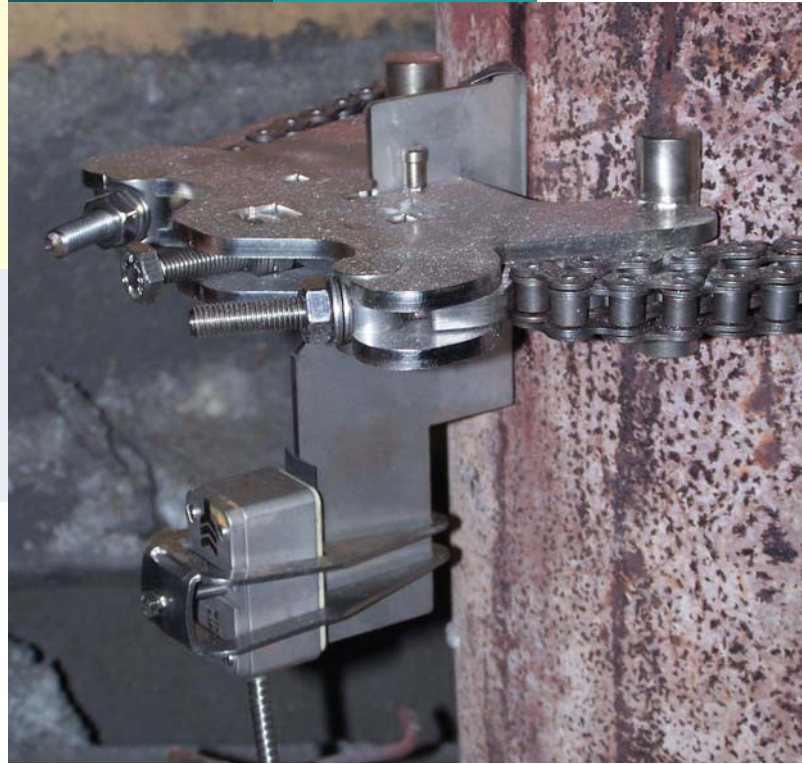

Non-intrusive flow measurement gives you a competitive edge – in process control, process management, and environmental protection.

FLEXIM's WaveInjector® has been specially engineered for high-temperature applications. Using patented technology, the WaveInjector® thermally separates the ultrasonic transducer from the hot pipe, allowing operation at process temperatures up to 750 °F.



The WaveInjector provides reliable measuring technology, field-proven under the toughest conditions in refinery applications worldwide.

Simple to install, reliable performance

The ultrasonic transducers are simply clamped to the outer surface of the pipe, using coupling plates for acoustic contact. There is no need to open the pipework, no drilling, and no process shut-down.

Once installed, the transducers do not suffer wear and tear from the process fluid, and they create no pressure drop. The FM, CSA and ATEX-certified transducers and transmitters are safe and reliable in potentially explosive atmospheres.

FLEXIM offers a wide range of ultrasonic transducers and transmitters to match any flow measurement application. The exceptionally high dynamic range of ultrasonic technology, 0.03 to 82 fps out-performs most other flowmeter types, offering big advantages when you need to measure widely-varying flow rates accurately.

Unique measuring technology

FLEXIM is the only producer of high-temperature non-intrusive clamp-on flowmeter technology worldwide. The WaveInjector® is used all over the world, by some of the biggest names in the process industries. The reason is clear: from crude oil to coal tar distillates. The WaveInjector® remains accurate and reliable under the toughest conditions.

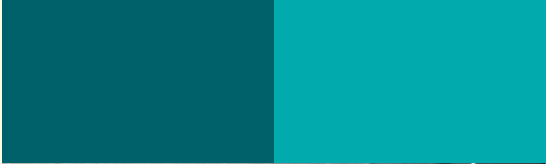

At a Glance:

Advantages of Clamp-On Measurement Using FLEXIM's Patented WaveInjector®

- Trouble-free operation at high temperatures
- No clogging, even with dirty or fouling fluids
- No pressure loss
- Install and maintain without process interruption
- No risk of leaks
- No pressure ports
- Fits all standard pipe sizes \geq DN 40 upwards
- Hazardous Area Certification
- Accurate and repeatable, even at low flows
- Wide dynamic range
- Independent of fluid or pressure
- Inherently Bi-directional



The Benefits:

- Increased Operator and Plant Safety
- Improved plant efficiency
- Increased environmental compliance
- Easier plant start-ups and upgrades
- Increased profits due to tighter process control
- Increased application flexibility
- Decreased start-up, operating and maintenance costs
- Decreased inventory costs for flowmeters and spare parts

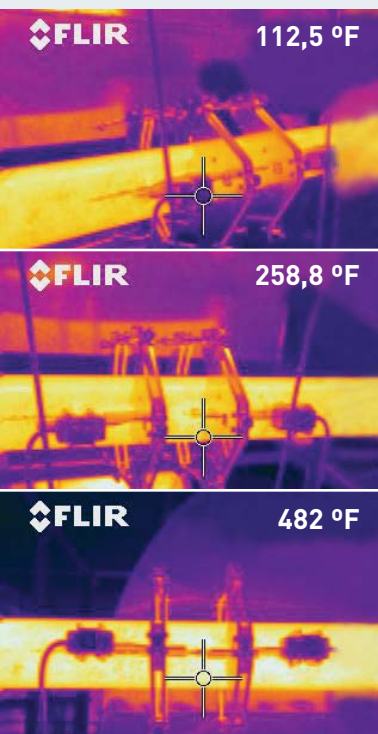

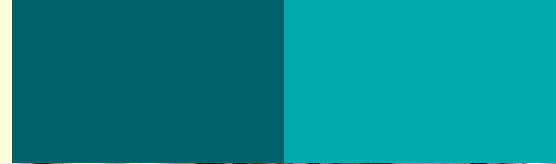

On Site: Reliable Flow Measurement with FLEXIM's WaveInjector®

Field-Proven Worldwide.

Flow Measurement of Heat Transfer Oil at High Temperatures



Identified Benefits:

Reliable non-intrusive flow measurement

Reliable process control

Easy retrofitting without opening the pipe and without process interruption

No risk of toxic leak

No wear and tear – no process interruption for inspection and maintenance

Higher plant availability

Protection of health and environment

In a Dutch refinery, a special heat transfer oil is used to supply process heat for the distillation columns. The oil is heated up to 570°F and conveyed through a system of thermally insulated pipes to the columns.

Effective operation of this installation requires reliable flow measurement of the oil. Before non-intrusive ultrasonic flow measurement technology was introduced, the flow was determined by means of a differential pressure measurement. Operations had to be stopped once a year in order to carry out the inspection and maintenance of the system. The medium is a car-cinogenic substance. Therefore all maintenance work required special preparation and precautions.

Non-intrusive flow measurement with clamp-on transducers and FLEXIM's WaveInjector® is a convenient and elegant solution to this measuring challenge. Since the transducers do not come in contact with the medium, there is no mechanical or chemical wear and tear. The meter can also be installed without opening the pipe, thus avoiding all risks of potentially dangerous leaks. Ultrasonic flow measurement thus offers the extra advantages that it is environmentally safe and improves plant safety and efficiency.



... Measurement of Highly Viscous Coker and Visbreaker Feed



Identified Benefits:

—
Reliable, non-intrusive measurement

—
Easy upgrading without intrusion into the pipe system and without process interruption

—
No risk of clogging of impulse piping (unlike the former measuring system)

—
No production interruption for installation or maintenance work

—
Reliable, maintenance free flow measurement

—
Wide dynamic measurement range

In a typical complex refinery operation, VAC tower residue or other high viscosity liquid streams are fed into cokers and/or vis-breakers for further processing. The flow of these hot liquids (> 390 °F) is traditionally measured with differential pressure devices (orifice or wedge meters) or vortex meters.

Under very severe process conditions, impulse line clogging and vortex shedders breakdown frequently. In these cases, increased maintenance costs or even process shut down can be required.

In a North American refinery, a differential pressure measurement was replaced without any process interruption with the non-intrusive Wavelnjector®, eliminating daily maintenance tasks. Furthermore, the wide dynamic range of the FLUXUS turned out to be of additional advantage. Previously four orifice plates were necessary to cover the entire measuring range. Now a single instrument does the job.

... Measurement of Bitumen at an Oil Sand Facility



Fortuitously for the customer, this test measurement revealed a control valve failure.

The refinery now uses the flow values delivered by the Wavelnjector® for a reliable mass balancing in the upgrader process.

In a Canadian oil sand surface mine recovered oil is refined directly on site. One of the many processing steps is thermal cracking. Optimally feeding the upgraded bitumen into the thermal cracker requires accurate monitoring and regulation of product input which can only be accomplished by reliable flow measurement. Some flow meters are also used for detection of line clogging. Clogged lines can easily cause a shutdown of the entire facility, leading to enormous downtime costs. In the past such measure-

ments were done with differential pressure methods or vortex shedding meters. Like all inline measuring instruments, these were subject to wear and tear and demanded daily maintenance.

Non-intrusive flow measurement proved to be a significantly better solution. A test measurement, using the Wavelnjector® together with a portable transmitter on a 6" pipe carrying hot VAC tower residue demonstrated the superiority of ultrasonic technology.

Identified Benefits:

—
Reliable non-intrusive measurement

—
Easy installation under problematic conditions

—
Straight forward installation with no need to open the pipe and no downtime

—
No corrosion or wear caused by the medium, thus long operating life

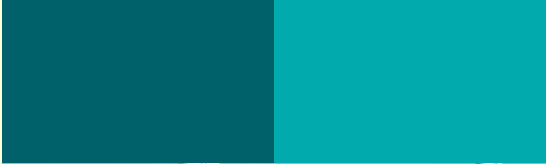

On Site: Reliable Flow Measurement with FLEXIM's WaveInjector®

Field-Proven Worldwide.

... Measurement of Overflash Mass Flow at 720°F

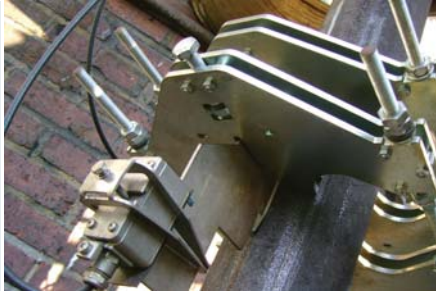

The overflash volume in atmospheric distillation is an important indicator for effective and well balanced operation of the distillation column. A precise measurement of this quantity poses a special challenge. Driven only by gravity, the medium moves at very low flow velocities of around 0.49 fsp, with a maximum flow rate of 10 tons/hr. Therefore, in order to reach a reasonable accuracy, the previously installed orifice plates had very small diameters. This resulted in a high pressure loss which could almost not be overcome by the hydrostatic conditions. Another challenge for the measuring system was the high medium temperature of around 720 °F.

After successful testing, a flow measuring system using FLEXIM's WaveInjector® was installed at the measuring point, which is located in an ATEX 1 explosion hazard zone. The installation was completed without any modification to the existing system.

The higher accuracy of the overflash measurement now allows a drastic improvement in process efficiency. The investment costs were quickly paid for by the higher yield.

Identified Benefits:

- **Reliable, non-intrusive measurement**
- **Measurement without any pressure losses**
- **Reliable measurement even at very low flow velocities**
- **Retrofitting and maintenance without interrupting plant operations**
- **Process optimization**
- **Easy upgrading without intrusion into the pipe system**
- **Highly improved accuracy in comparison to conventional orifice meters**



... Measurement of Heavy Gasoil in a Vacuum Distillation Tower



In one of the most complex refineries in Europe, replacement for an unreliable flow measurement system was sought. The measuring point was located at the heavy gas oil outlet of the vacuum distillation tower, in an ATEX zone 1 rated area. The gasoil flowing there had a temperature of approximately 570 °F.

In this case too, clamp-on flow measurement with a Wavelnjector® was the best suited measuring technology. Due to the high dynamic range of the meter, even small flows could be measured. Since the transducers were clamped onto the pipe, the meter was not subject to wear and tear.

Identified Benefits:

-
- Easy upgrading without pipe work and without process stoppage**
-
- Reliable non-intrusive flow measurement**
-
- No influence on the process – no pressure drop**
-
- Reliable measurement even at very low flow velocities**
-
- Retrofitting & maintenance without affecting the plant**
-
- Process optimization**
-
- Greater accuracy than conventional orifice meters**

... Measurement of Bitumen at 700°F



Accurate, drift-free measurement is possible, even with large nominal pipe sizes. The robust measuring system is not harmed by either by hot steam purging or by short term overheating.

Identified Benefits:

-
- Reliable, non-intrusive, maintenance-free flow measurement**
-
- No risk of clogging of impulse piping (unlike conventional measuring systems)**
-
- No deposit formation, no parts subject to wear and tear**
-
- No production interruption for installation or maintenance work**
-
- Simple, speedy installation, no pipe work**

Today, rising economic pressure is forcing major refineries to steadily increase the throughput of their facilities. Reliable flow measurement is crucial to the optimization of production processes. Refined bitumen, which is produced by means of vacuum distillation at temperatures around 700 °F, poses a special challenge to flow measurement technology because of its high temperature and high viscosity.

Intrusive flow meters face problems inherent to their technologies: clogging of impulse piping, deposit formation, etc. These problems result in frequent shut-downs, high maintenance costs and reduced throughput.

FLEXIM's answer to these problems is the non-intrusive Wavelnjector® – ideally suited for high temperatures up to 750 °F. There are no movable parts which could be subject to wear and tear. There are no limitations to medium pressure. Its installation will not require any down time.



On Site: Reliable Flow Measurement with FLEXIM's Wavelnjector®

Field-Proven Worldwide.

... Measurement of Hot Pitch During the Distillation of Coal Tar



In one of the world's largest coal tar refineries, the delivered raw material is distilled to obtain technical oils and aromatics, which serve as valuable basic materials for the dye and pharmaceutical industries.

Adverse process conditions and media characteristics make flow measurement of pitches a difficult task. Due to the high solid content of the pitch; orifice plates quickly lose their sharpness, and thus their measuring accuracy. Furthermore, pressure impulse lines are quickly clogged by deposit formation. Due to thermal stress, Coriolis or Vortex flow meters fail prematurely.

Flow measurement based on ultrasonic clamp-on procedure using the patented Wavelnjector® is a superior solution to this problem. Based on convincing experience in tar distillation, wetted measuring systems in the entire plant are being replaced gradually by the non-intrusive FLUXUS® ultrasonic measuring systems.

Identified Benefits:

Reliable and low-maintenance flow measurement

No mechanical wear due to the abrasive pitch

Reliable high temperature measurement with the Wavelnjector®, not affected by temperature shocks

High measurement accuracy

Excellent measuring dynamics

No reduction of pipe size, no moving parts, no pressure loss

No leakage risk of the highly combustible and environmentally dangerous medium

Simple installation and start-up of the non-intrusive measuring system without work on pipes and down-time

Certified transducers and transmitters for operation in hazardous areas



... Measurement of Different Media, such as Tar, Machine Oils, Glycol Mixes, Carbonate Lye, Cracker Ethylene, Cooling Water, Hot Water, etc.



Identified Benefits:

— **Accurate non-intrusive flow measurement**

— **Quick installation and start-up of the measuring equipment on the filled pipeline, without process interruption.**

— **No risk of leakage**

— **No wear due to the chemically aggressive media**

— **High measuring accuracy, even under unfavorable measuring conditions**

— **Wide dynamic range assures precise measurements for low as well as high flow rates**

— **One single measuring system for a multitude of different applications**

— **Robust measuring system: solidly made transmitters, ultrasonic transducers and connection cables for use in humid and rough environments**

— **More than 14 hours of battery-powered measurement, display of battery status**

— **Complete measuring system in a practical, sturdy transport case**

The Special Measuring Technology Department of one of the leading producers of petrochemical products faces various challenges daily:

- Control of permanently installed measuring systems.
- Temporary replacement of defective devices.
- Flow measurement at places where no stationary measuring system is installed, for diagnostic purposes or for process optimization.

In all these cases, the experts reach for their FLEXIM measuring case: the non-intrusive acoustic measuring technology offers maximum flexibility. The ultrasonic transducers are simply clamped onto the pipe, and quickly installed, without cutting into the pipe and without process interruption. For many different applications, the department uses a Wavelnjector® together with transducers selected for the respective measuring task. The handy portable transmitter; easily fixed even at measuring points with difficult access, automatically recognizes the connected transducers.



FLEXIM's WaveInjector®

Non-intrusive flow measurement at extreme temperatures

Ultrasonic flow measurement at high temperatures was until now a troublesome business: The gels or pads used for acoustic coupling between the transducers and the pipe have a limited temperature tolerance. Furthermore, high temperatures accelerate the aging of the ultrasonic transducer's piezo elements and thus limit their useful operating life.

FLEXIM's newly patented WaveInjector® overcomes these limitations.

The patented transducer mounting fixture realizes a long-term stable clamp-on ultrasonic flow measurement with standard temperature transducers at temperatures as high as 750 °F. It offers all the advantages of the clamp-on ultrasonic technology, a non-intrusive measurement, and a wide dynamic range with a high flexibility.

The WaveInjector® is available in various sizes, each of which covers a wide nominal pipe diameter range. For big pipes; special mounting chains ensure a firm attachment to the pipe, thus assuring high pressure on the coupling point.

Since the WaveInjector® is a purely mechanical device, it can be used in explosion hazard areas without any further certifications.



WaveInjector® and ultrasonic transducers are installed without interrupting the process

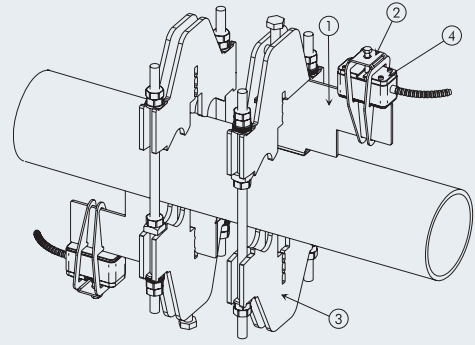

The Wavelnjector®

The Wavelnjector® is composed of the Wavelnjector® coupling plate (1), the transducers clamping fixtures (2), a pipe mounting clamp (3), together with an acoustic coupling foil. The metallic coupling plate between the transducer (4) and the pipe provides nearly loss-free ultrasonic coupling. At the same time, its cooling effect maintains a high temperature gradient between the surface of the pipe and the coupling surface of the transducer. This guarantees that the maximum permissible transducer temperature is never exceeded.

The robust pipe mounting assembly (3) ensures a high surface pressure between the coupling plates and the pipe wall. Special metallic foils guarantee an optimal long term stable acoustic coupling.

Temperature profile of the Wavelnjector®

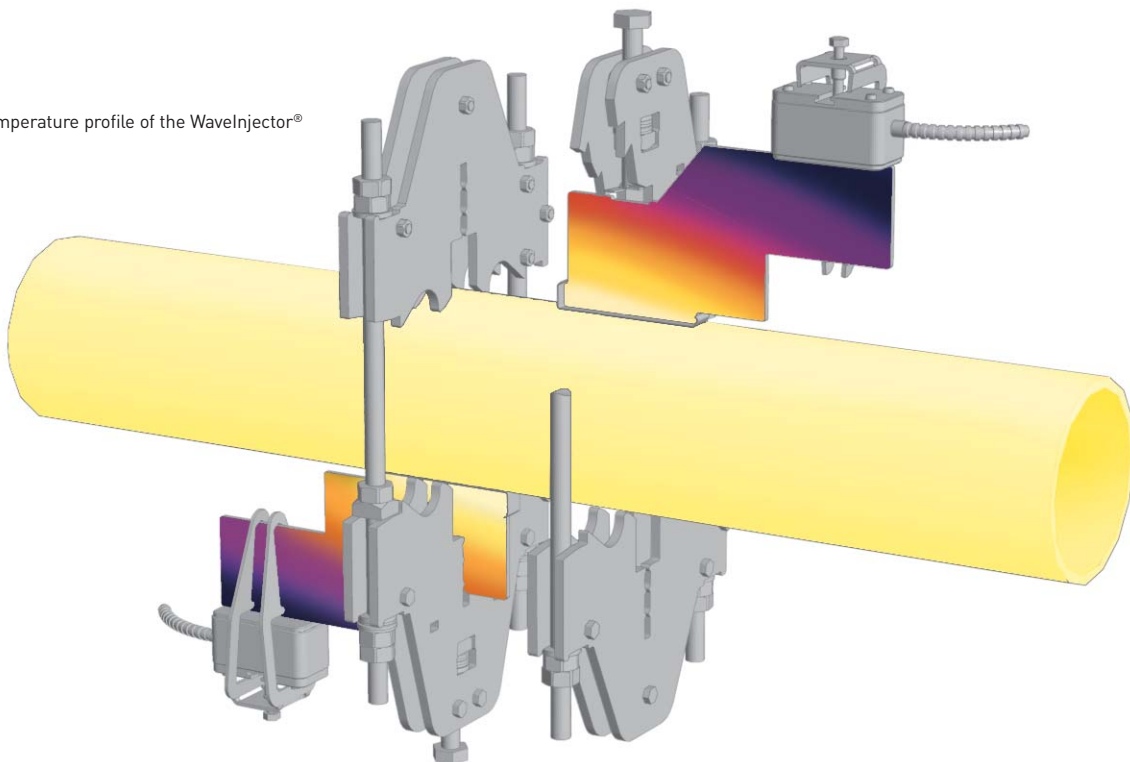

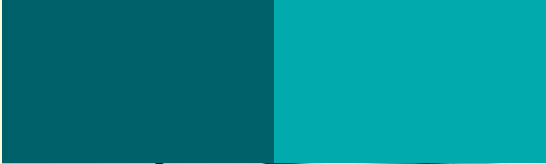

The Future has Begun.



WavelInjector®

The WavelInjector® is a special transducer mounting fixture which makes it possible to use standard ultrasonic flow transducers at extreme temperatures.

Temperature range:

-160 °C to 400 °C (-250 °F to 750 °F)

Pipe diameter range:

40 mm to 1000 mm (1.6 in to 39 in)

Material:

Stainless steel

Hazardous area classification:

Since the WavelInjector® is a purely mechanical device, it can be used without any further certification in explosion hazard areas.



The transducers:

All FLEXIM transducers are calibrated as a pair at the FLEXIM factory in Berlin. The calibration can be traced back to national and international standards. The calibration data and the transducer parameters are permanently stored in the transducers themselves. As well, an extended calibration can be carried out on demand.

Operating temperature, standard transducers:

-40 °C to 130 °C (-40 °F to 266 °F)

Operating temperature, high temperature transducers:

-30 °C to 200 °C (-22 °F to 392 °F)

Operating temperature with WavelInjector®:

up to 400 °C (750 °F)

Degree of protection:

IP65, IP67 or IP68 depending on type (EN60529); NEMA 4X

Material:



Stainless steel or PEEK with stainless steel protective cap

Hazardous area classification:

FM Class I Div II and ATEX zone 1 & 2 types available



The matched FLUXUS® flowmeters:

| | | |
|---|-------------------------------------|--|
|  | <p>FLUXUS® F601</p> | <p>The portable meter</p> <p>Operating temperature: -10 °C to 60 °C (14 °F to 140 °F)</p> <p>Flow channels: 2</p> <p>Degree of protection: Transmitter: IP65 gem. EN60529; NEMA 4X Transport case: IP67 gem. EN60529; NEMA 4X</p> |
|  | <p>FLUXUS® ADM 7407/7907</p> | <p>The multi-function meters</p> <p>Operating temperature: -10 °C to 60 °C (14 °F to 140 °F)</p> <p>Flow channels: 1 or 2</p> <p>Degree of protection acc to EN60529: ADM 7407: IP65; NEMA 4X ADM 7907: IP20; NEMA 1</p> <p>Hazardous area classification: ADM 7407: ATEX zone 2 or FM Class I Div II optional</p> |
|  | <p>FLUXUS® ADM 8027/8127</p> | <p>The explosion-proof experts</p> <p>Operating temperature: ADM 8027: -20 °C to 60 °C (14 °F to 140 °F) ADM 8127: -20 °C to 50 °C (14 °F to 122 °F)</p> <p>Flow channels: 1 or 2</p> <p>Degree of protection: IP66 acc. to EN60529</p> <p>Hazardous area classification: FM, CSA and ATEX</p> |



FLEXIM

A short portrait



For nearly 20 years now, FLEXIM has been an active leader in many areas of process instrumentation in both national and international markets. In addition to non-intrusive flow measurement, FLEXIM specializes in innovative online process analysis using ultrasonic technology and refractometry.

Year after year, FLEXIM continues its substantial investment in research and development in order to maintain and further improve its position as an industry leader. In addition, FLEXIM maintains a close contact to its customers. Innovative and reliable products meeting exactly the needs of the customer are the result.

Competent and professional associates in our sales offices and regional headquarters in Europe, North America, Asia and all over the world ensure the worldwide distribution of FLEXIM's proven technology and guarantee you qualified service.



BUREFINERY1-1US Subject to change without notification. 2010/02

FLEXIM AMERICAS Corporation

Headquarters
250-V Executive Drive
Edgewood, NY 11717
Phone: (631) 492-2300
Fax: (631) 492-2117
Toll free: 1-888-852-7473
(North America only)
www.flexim.com
usinfo@flexim.com

FLEXIM Instruments Asia Pte Ltd

Singapore
Phone: +65 67 94-53 25
Fax: +65 68 62-28 36
asia@flexim.com

Shanghai, China
Tel.: +86 (21) 649 575 20
shanghai@flexim.com

FLEXIM GmbH

Berlin, Germany
Tel.: +49 30 93 66 76-60
Fax: +49 30 93 66 76-80
info@flexim.de
www.flexim.de

