

# Advanced Metering Technology

## Ultrasonic Flow Measurement in Gas Storage Operations

Field-proven. Accurate. Safe.

### Underground gas storage operations

- Gas at the wellhead
- Injection of inhibitors
- Gas dehydration
- Hydrocarbon dew point reduction
- Gas compression

### In-situ leaching for gas storage

- Brine density and flow
- Blanket check

### Liquefied natural gas



**External Measurement  
of Internal Flow**

## The better solution.

# Non-intrusive flow measurement with FLUXUS®

**Most flows go in one direction only. However, this is not the case in a natural gas storage facility. Here, gas is either stored or removed depending on the market situation, an ideal application for clamp-on ultrasonic flow measurement with FLUXUS®.**

Operators of gas storage facilities face specific measurement challenges: high pressure and flow rates during injection and even higher flow rates during withdrawal. The withdrawn gas is saturated with water-vapor and can carry free water, depending on the geological formation of the reservoir.

### Leading technology

In many applications all over the world, FLEXIM's non-intrusive clamp-on ultrasonic flow measurement with FLUXUS® G proves to be the most suitable solution. FLEXIM's FLUXUS® G gas flow meters work according to the same principle as their wetted counterparts, the transit-time difference principle (time of flight).

Compared to differential pressure devices such as orifices, the acoustic method offers accurate and reliable measurement over an almost unlimited flow range, regardless of the flow direction. As the transducers are simply clamped onto the outside of the pipe, they are not exposed to wear and tear and do not cause any pressure loss. Installation does not require any pipework and can easily take place during ongoing operation. FLEXIM's FLUXUS® G series comprises permanent and portable gas flowmeters certified for ATEX zones 1 and 2, FM and CSA Class 1. FLUXUS® G transmitters are the only ones that support both Lamb and shear wave transducers. As a result, the measuring system can be adapted to the most demanding applications. Each pair of transducers is wet-flow calibrated at the factory. All calibration data is stored in a transducer-resident non-volatile memory and is automatically transferred to the transmitter upon connection.



### Approved accuracy

Today, FLUXUS® G stands its ground in gas storage operations worldwide. FLEXIM's ultrasonic gas flowmeters have been approved by major gas companies. Renowned and independent calibration rigs and laboratories have tested and verified their performance.

Driven by the requirements of UGS operations, a recent study was conducted at the Colorado Experiment Engineering Station Inc. (CEESI) with the aim of verifying the capabilities of FLUXUS® G under wet gas conditions. Even at elevated liquid volume fractions, the flowmeter showed reliable readings.

The advantages of non-intrusive ultra-sonic flow measurement are certainly not confined to the gaseous state. The FLUXUS® F is the ideal solution for the measurement of liquids such as produced water or glycol. Together with FLEXIM's patented WaveInjector® for measurement at extreme temperatures, FLUXUS® F can even be used to measure Liquefied Natural Gas (LNG).

For more information:

[www.ugs.flexim.com](http://www.ugs.flexim.com)





## Unique features of FLEXIM's FLUXUS® G series:

- Every set of transducers is wet-calibrated and supplied with a traceable calibration certificate
- Matched and paired transducers ensuring unequalled out-of-the-box accuracy
- Capable of measuring wet gas
- Virtually maintenance-free due to permanent coupling pads
- Transmitter supports both shear wave and Lamb wave transducers
- Compliant with ANSI/ASME MFC-5M-1985(R2001) (temperature compensation)
- Up to 1000 measuring cycles per second guarantee stable and precise flow readings

## Technical facts:

Measuring principle:	Transit-time difference correlation principle
Flow velocity:	0.03 to 115 ft/s, depending on the pipe size
Repeatability:	0.15% of reading +/- 0.03 ft/s
Accuracy (given a fully developed rotationally symmetric flow profile):	Volume flow: +/- 1% to 3% of reading +/- 0.03 ft/s, depending on the application +/- 0.5% of reading +/- 0.03 ft/s with field calibration
Pipe size range:	0.8 to 63 in
Pipe wall thickness:	0.02 to 2 in
Operating pressure:	No pressure limitations

## Main advantages of clamp-on flow measurement with FLUXUS® in gas storage applications:

- Bidirectional; measures flow in either direction
- Very wide dynamic flow range, turndown > 100:1
- No pressure loss
- Unaffected by gas contaminants and wetness
- Unaffected by noise of valves or compressors
- Accurate and reproducible, even at low flow rates
- Outstanding long-term stable accuracy
- Works independently of the conductivity and pressure of the medium
- Fits all pipe sizes and works on thick pipe walls
- Measurement in actual and normalized gas volume units
- Robust measurement systems, even for use in offshore applications
- No risk of leakages
- No wear and tear, no clogging
- Certified for hazardous areas; higher levels of operator and plant safety
- Applicable on pipes with cathodic protection

# Field-proven clamp-on flow measurement

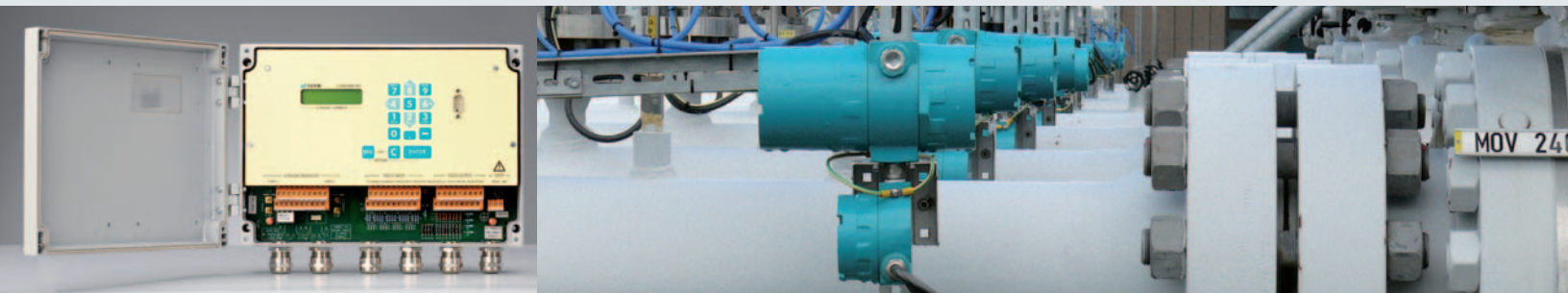

## Underground gas storage

Underground storage of natural gas can take place in depleted reservoirs, in aquifers or in caverns previously leached out of subsurface salt formations.

Although each storage type has its own characteristics, all underground gas storage operations face similar challenges: highly dynamic bidirectional gas flow under high pressure, wet withdrawn gas which must be dried before

being fed back into the transportation network, prevention of hydrate formation, reduction or increase in gas pressures.

FLEXIM's FLUXUS® clamp-on flow-meters are used every step of the way.

For more information:

[www.ugs.flexim.com](http://www.ugs.flexim.com)





## 1 Gas at the wellhead

Depending on the storage type, pressure can reach considerable levels (4000+ psi) during gas injection and withdrawal. Conventional differential pressure instruments are both lacking in accuracy and reliability. Due to their small turndown ratio, they usually work in a cascading fashion to cover the wide flow range, thus entailing large pressure losses. They are also subject to wear and tear. The tiny pressure taps for orifice plates are particularly exposed to clogging due to the possible formation of hydrates or gas contaminants. This results in excessive maintenance efforts associated with pipework and therefore partial downtimes of plant sections.

Measuring simply from the outside of the pipe clearly proves to be the better solution. Acoustic measurement offers high accuracy in both flow directions over an extremely large measurement range. Therefore, one FLUXUS® G replaces two or more conventional flowmeters. As the clamp-on transducers do not come into direct contact with the gas flowing inside, they are not affected by solid particles, hydrates or by high moisture contents. In addition, non-intrusive gas flow measurement with FLUXUS® G does not cause any pressure loss and therefore does not negatively affect the energy efficiency of the plant.

## 2 Injection of inhibitors

The formation of hydrates can have a major impact on the plant's operability. In the worst case scenario, these solid crystalline structures, which resemble ice or wet snow, can clog the pipe thereby leading to process interruption and expensive maintenance work. In order to prevent their formation, hydrate inhibitors are injected into the wellbore. Piston pumps are usually used for injection, producing pulsating, highly dynamic flow under high pressure.

FLUXUS® F is the ideal solution for monitoring the dose rate of the injected chemicals. Clamp-on ultrasonic flow measurement works independently of the pressure in the pipe and is unaffected by pulsations in pressure and flow.

## 3 Gas dehydration

Moisture is the cause of hydrate formation and corrosion. Withdrawn gas must therefore be dried to meet the requirements of the pipeline market. The dehydration

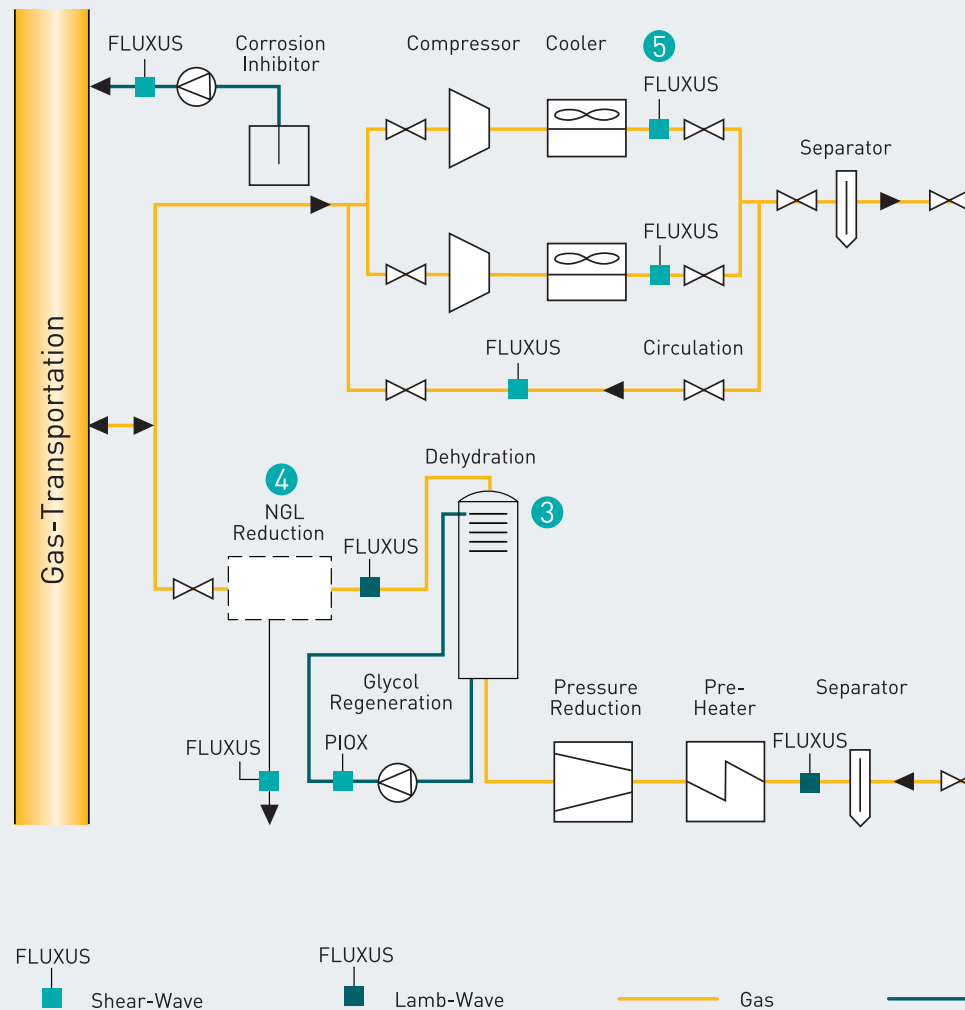

procedure comprises mechanical and thermodynamical process steps whereby FLUXUS® G is used for measuring the gas flow and FLUXUS® F is used for measuring the quantity of removed water.

The final stage of dehydration typically takes place in absorption towers, where the remaining humidity is captured by highly hygroscopic chemicals, e.g. glycols. FLUXUS® also offers the ideal solution for both liquid and gas flow measurement here. Glycol pumps can malfunction due to glycol corrosion or glycol lines can become

clogged. FLUXUS® F reliably monitors glycol pump functionality and therefore helps prevent operational losses.

The US Environmental Protection Agency (EPA) estimates that 17 BCF of methane are lost each year through dehydration and pump inefficiencies: "Methane emissions are directly proportional to glycol overcirculation." By measuring the concentration and flowrate of circulated glycol with FLEXIM's non-intrusive technology, such methane losses can be minimized.

#### 4 Hydrocarbon dew point reduction

When gas is stored and withdrawn from depleted oil fields it often contains natural gas liquids (NGLs). The NGL dew point has to meet pipeline specifications. Dew point reduction is carried out by pressure reducing methods (Joule-Thomson) or by means of various cryogenic schemes. Gas flow measurement in such operations is important to ensure accurate gas intake flow velocities and the correct flow balance.

#### 5 Compressor operations

Compressor operations can be easily and effectively monitored with FLUXUS® G. Compressor flow intake measurement ensures a balanced and sufficient gas load. Maintenance issues or possible compressor surge issues are thereby noticed well in advance of costly equipment damage.

#### Related applications

FLEXIM's FLUXUS® clamp-on flowmeters cover a wide range of applications in underground storage operations. In particular, this includes storage of other fluids such as:

- Oil
- Compressed air
- Carbon dioxide

Similar processes are also applied in the exploration and production, transportation and distribution of natural gas, where FLUXUS® is widely used as well; e.g. for flow measurement in the following operations:

- Gas production
- Water injection
- Gas dehydration
- Gas sweetening
- Transportation network
- Distribution network

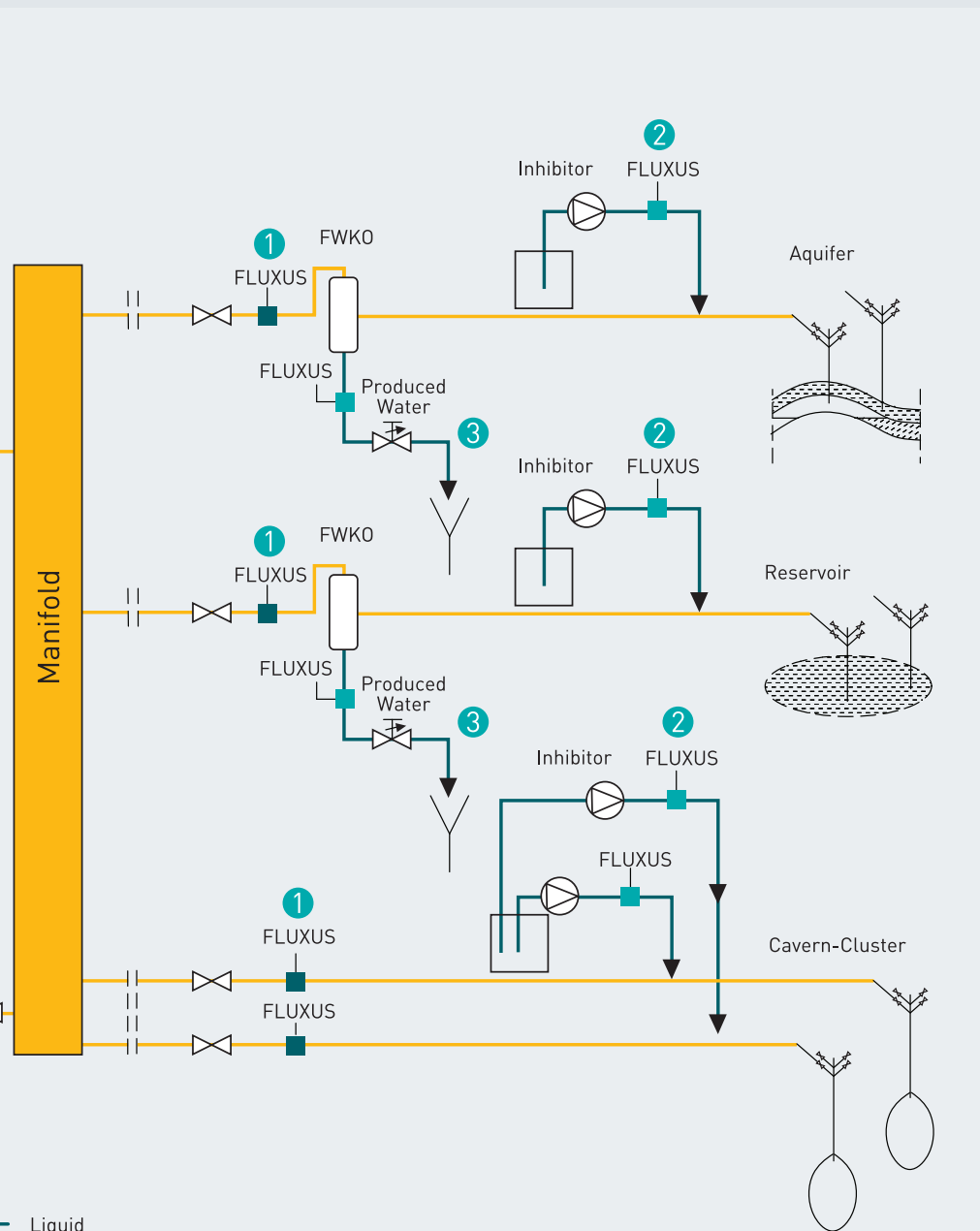

## In-situ leaching for gas storage

Underground gas storage in salt caverns starts out with the leaching of the cavern by solution mining. This process requires flow measurement of the injection water as well as the produced brine. FLEXIM's FLUXUS® F ultrasonic flowmeters have proven successful in solution mining applications due to their unparalleled versatility.

FLEXIM's ultrasonic clamp-on technology allows for non-intrusive, highly accurate measurement of water and brine flow. By measuring the sound speed, the same instrument can be used to determine the density of the produced brine at the same time. FLUXUS® is also used for blanket measurement.

- Simultaneous non-intrusive flow and density measurement with one instrument
- Pressure independent
- Not subject to corrosion through salt
- No wear and tear, not affected by solid particles (i.e. sand and stones in the brine)
- No risk of leakages
- Installation without process downtime

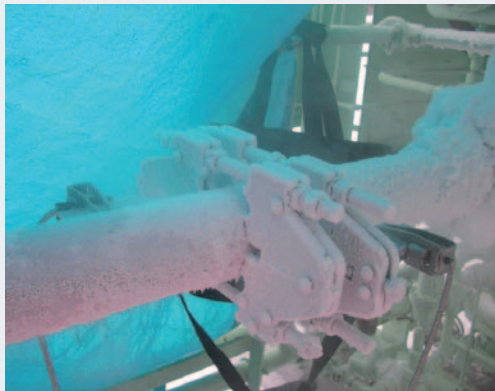
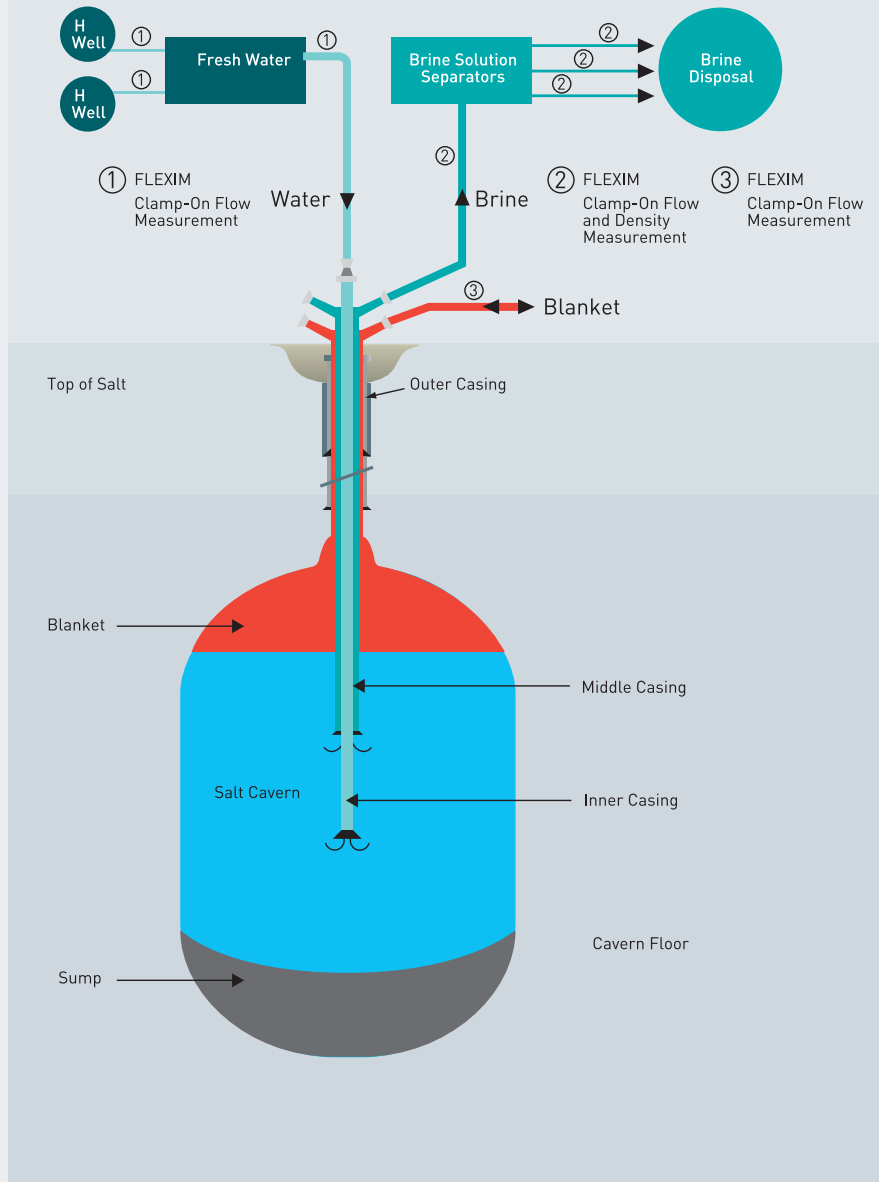

## LNG – Liquefied Natural Gas

At LNG plants, terminals and storage facilities natural gas is handled in liquefied form at a temperature of -262 °F. Such extreme conditions present special challenges for most common metering principles. FLEXIM's patented WaveInjector® technology provides a non-intrusive solution for these applications and therefore overcomes typical problems associated with intrusive metering methods. The thermally separated ultrasonic transducers offer a reliable and proven way to measure LNG flow without causing any pressure drop.

# FLEXIM

**In Partnership  
with you**



FLEXIM is an active leader in many areas of process instrumentation. As a worldwide pioneer in the non-intrusive flow measurement of liquids and gases, FLEXIM has been leading the way in ultrasonic clamp-on flow metering for more than 20 years. In addition to non-intrusive flow measurement, FLEXIM specializes in innovative online process analysis using ultrasonic technology and refractometry.

Year after year, the Berlin-based company continues its substantial investment in research and development in order to maintain and further improve its position as an industry leader. In keeping with its core principles, FLEXIM takes customer feedback very seriously. Every generation of FLEXIM products is directly driven by customer and industry needs.

### The FLEXIM Commitment to Customer Service

FLEXIM considers itself not only a manufacturer of measuring instruments, but also a provider of technical and consulting services. These services include on-site measurements, laboratory analysis, project

handling, training, commissioning, instrument rentals and consulting services.

The company's focus and dedication is directed towards providing the highest-quality equipment with the best support and service possible.

### FLEXIM Oil & Gas

The hydrocarbon processing industry (HPI) has special demands: high pressures, extreme temperatures and always high safety requirements. FLEXIM's product portfolio offers measurement solutions which ideally meet those expectations. In order to better serve the needs of the hydrocarbon industry, FLEXIM has founded a global network of experts in HPI applications with supporting offices in many parts of America, Europe and Asia. The FLEXIM Oil & Gas division has many years of experience and has been widely accepted by the world's major oil and gas companies.

### FLEXIM GmbH

Berlin, Germany  
Phone: +49 30 93 66 76 60  
Fax: +49 30 93 66 76 80  
[info@flexim.de](mailto:info@flexim.de)

### FLEXIM AMERICAS Corporation

Edgewood, NY, USA  
Phone: +1 631 492 23 00  
Fax: +1 631 492 21 17  
Toll free: 1 888 852 74 73  
(North America only)  
[usinfo@flexim.com](mailto:usinfo@flexim.com)

### FLEXIM Instruments Asia Pte Ltd.

Singapore  
Phone: +65 67 94 53 25  
Fax: +65 68 62 28 36  
[salessg@flexim.com](mailto:salessg@flexim.com)

Shanghai, China  
Phone: +86 21 64 95 75 20  
[shanghai@flexim.com](mailto:shanghai@flexim.com)

Visit us at:  
[www.flexim.com](http://www.flexim.com)  
[www.ugs.flexim.com](http://www.ugs.flexim.com)